

Pallet Mover PM1500 and PM1548

The Pallet Mover PM1500 and PM1548 enable the mobile robots MiR500 and MiR1000 to pick up and deliver pallets - transporting them to e.g. production lines or packing stations, thereby **enhancing internal logistics**.

The Pallet Movers integrated technology enables communication to external roller conveyors by infrared signals. This fully automated premium solution allows heavy payload transportation of up to 1500 kg to optimize internal logistics and production.

Key benefits

- Heavy payload transportation
- Transport of US and EU pallets, as well as half pallet size
- Integrated technology
- Safe driving with a heavy load
- Allows the fixing of various pallet sizes

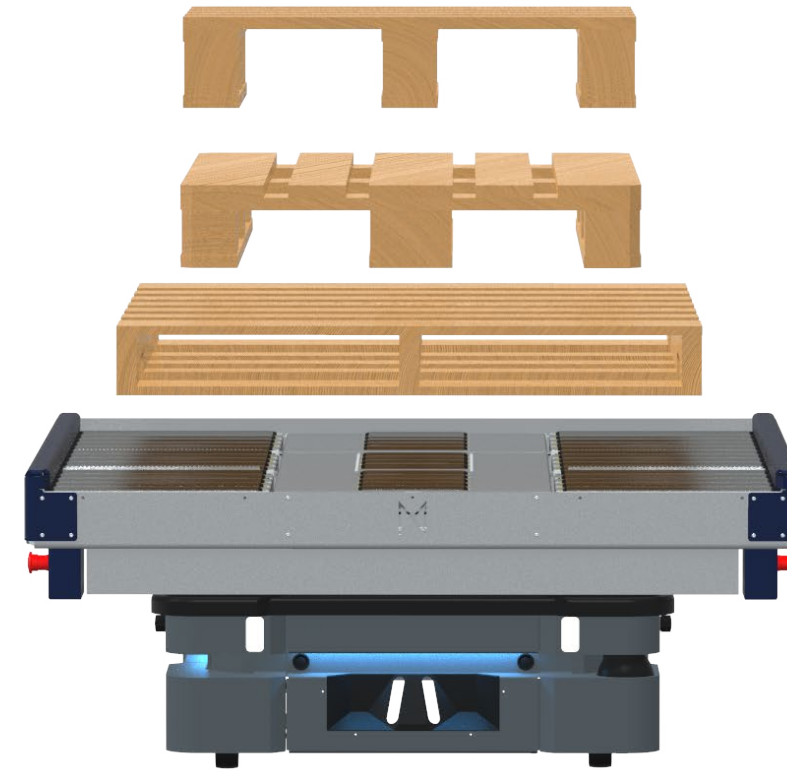

PM1548 with half-, EU- and US-pallet

WORKS WITH

PC0800, Pallet Conveyor
 PC1000, Pallet Conveyor
 PC1200, Pallet Conveyor
 PM400, VL Marker
 PM1548, VL Marker
 External conveyors



Technical specifications

Parameter	PM1500, Pallet Mover	PM1548, Pallet Mover
Dimensions (LWH)	1346 x 1124 x 137 mm 53" x 44" x 5.4"	1346 x 1344 x 188 mm 53" x 53" x 7.4"
Handling capacity	up to 1500 kg 3306 lbs	up to 1500 kg 3306 lbs
Transport area	1320 x 1036 mm 52" x 41"	1320 x 1256 mm 52" x 49.45"
Conveyor weight	130 kg 287 lbs	192 kg 423 lbs
Conveyor working height	426 mm 16.77"	508 mm 20"
Color	RAL 7035	RAL 7035
Pitch between rolls	Side rollers: 90 mm 3.54" Middle rollers: 82.5 mm 3.25"	Side rollers: 90 mm 3.54" Middle rollers: 82.5 mm 3.25"